



COURSE TECHNOLOGY
CENGAGE Learning™

A+ Guide to Managing and Maintaining Your PC, 7e

Chapter 6 *Supporting Processors*

Objectives

- Learn about the characteristics and purposes of Intel and AMD processors used for personal computers
- Learn about the methods and devices for keeping a system cool
- Learn how to install and upgrade a processor
- Learn how to solve problems with the processor, the motherboard, overheating, and booting the PC

Types and Characteristics of Processors

- Processor
 - Installed on motherboard
 - Determines system computing power
- Two major processor manufacturers
 - Intel and AMD

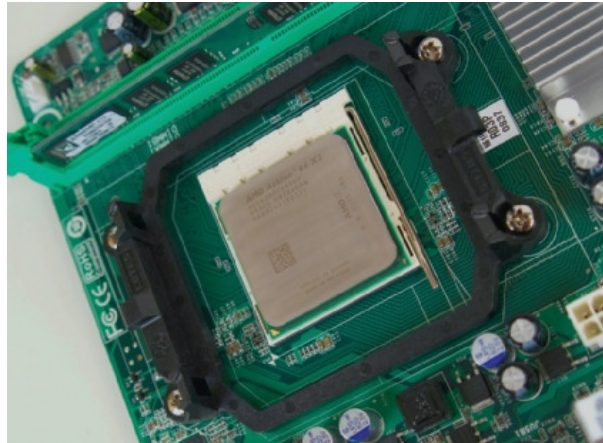

Figure 6-1 An AMD Athlon 64 X2 installed in socket AM2+ with cooler not yet installed
Courtesy: Course Technology/Cengage Learning

Types and Characteristics of Processors (cont'd.)

- Features affecting processor performance and motherboards
 - System bus speeds the processor supports
 - Processor core frequency
 - Motherboard socket and chipset
 - Multiprocessing ability
 - Memory cache
 - Amount and type of DDR, DDR2, DDR3 memory
 - Computing technologies the processor can use
 - Voltage and power consumption

How a Processor Works

- Three basic components
 - Input/output (I/O) unit
 - Manages data and instructions entering and leaving the processor
 - Control unit
 - Manages all activities inside the processor
 - One or more arithmetic logic units (ALUs)
 - Performs all logical comparisons, calculations

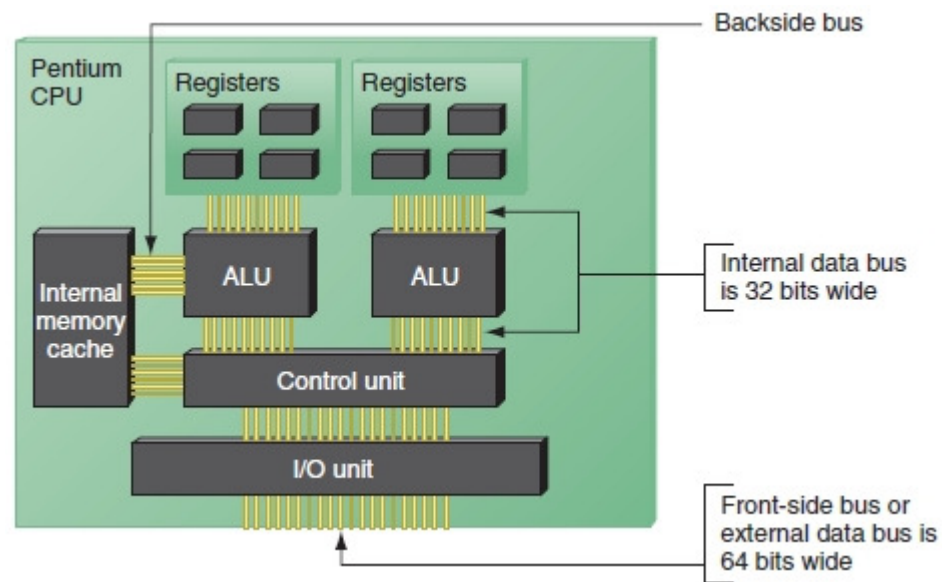

Figure 6-2 Since the Pentium processor was first released in 1993, the standard has been for a processor to have two arithmetic logic units so that it can process two instructions at once
 Courtesy: Course Technology/Cengage Learning

How a Processor Works (cont'd.)

- Registers
 - Small holding areas on processor chip
 - Holds counters, data, instructions, and addresses ALU is currently processing
- Processor internal memory caches (L1, L2, L3)
 - Holds data and instructions to be processed by ALU
- Busses
 - Front-side bus (FSB)
 - Internal
 - Back-side bus (BSB)

How a Processor Works (cont'd.)

- Processor frequency (speed)
 - Speed at which processor operates internally
- Multiplier
 - Factor multiplied against system bus frequency
 - Determines processor frequency
 - System bus frequency \times multiplier = processor frequency
- Motherboard firmware
 - Automatically detects processor speed, adjusts system bus speed accordingly

How a Processor Works (cont'd.)

- Overclocking
 - Running motherboard or processor at higher speed than manufacturer suggests
 - Override default frequencies
 - Change setting in BIOS setup
 - Disadvantages
 - Overheating
 - Voids most warranties
 - Not recommended in business environment

How a Processor Works (cont'd.)

- Throttling
 - Offers some protection against overheating
 - Throttle down, shut down system prevents permanent processor damage
 - Reduces power consumption when demands low
 - PowerNow! by AMD
 - Enhanced Intel SpeedStep Technology (EIST) by Intel

How a Processor Works (cont'd.)

- Three methods to improve performance
 - Multiprocessing
 - Processor contains more than one ALU
 - Multiple processors
 - Installing more than one processor on a motherboard
 - Multi-core processing
 - Processor housing contains two or more cores operating at same frequency, independently of each other
 - Dual core, triple core, quad core, octo core

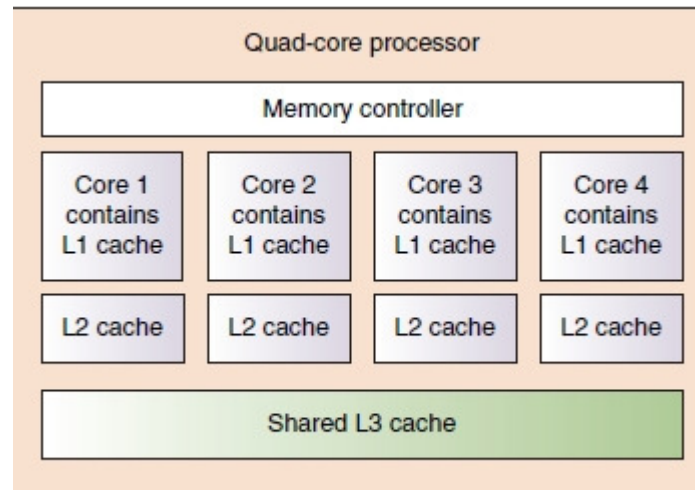

Figure 6-4 Quad-core processing with L1, L2, and L3 cache and the memory controller within the processor housing

Courtesy: Course Technology/Cengage Learning

How a Processor Works (cont'd.)

- Memory cache (L1, L2, or L3)
 - Holds anticipated data and instructions needed by controller
 - Improves performance
 - Static RAM (SRAM)
 - Holds data as long as power on
 - Lets processor bypass slower dynamic RAM (DRAM)
- Memory controller
 - Included in processor package
 - Significant increase in system performance

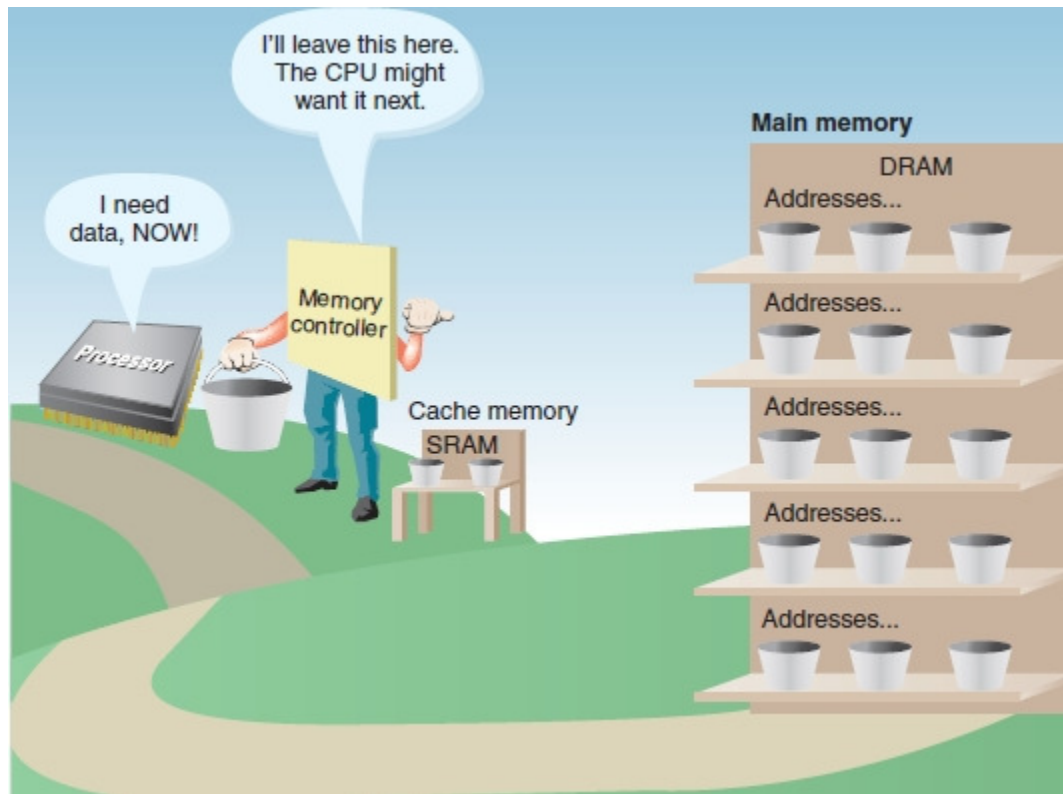

Figure 6-5 Cache memory (SRAM) is used to temporarily hold data in expectation of what the processor will request next
Courtesy: Course Technology/Cengage Learning

How a Processor Works (cont'd.)

- Instruction set
 - Microcode used for basic operations
- Processor computing technologies
 - MMX (Multimedia Extensions) and SSE (Streaming SIMD Extension)
 - 3DNow! and SSE2
 - Intel Hyper-Threading and AMD HyperTransport
 - PowerNow! and Cool'n'Quiet
 - Enhanced Intel SpeedStep Technology (EIST)
 - Execute Disable Bit
 - 32-bit and 64-bit instructions, operating systems

Intel Processors

Processor	Clock Speed	Front Side Bus	Description
Core Family			
Core i7 Extreme	3.20GHz	6.4 GT/s	8 MB cache, quad-core, DDR3 memory, desktop
Core i7	2.66 to 2.93 GHz	4.8 GT/s	8 MB cache, quad-core, DDR3 memory, desktop
Core 2 Extreme	2.53 to 3.2 GHz	800 to 1600 MHz	4 to 12 MB cache, quad-core, dual-core, desktop, or mobile
Core 2 Quad	2.0 to 3.0 GHz	1066 to 1333 MHz	4 to 12 MB cache, quad-core, desktop, or mobile
Core 2 Duo	1.06 to 3.33 MHz	533 to 1333 MHz	2 to 6 MB cache, dual-core, desktop, or mobile
Core Duo	1.5 to 2.33 GHz	533 to 667 MHz	2 MB cache, dual-core, desktop, or mobile
Core 2 Solo	1.06 to 1.2 GHz	533 or 800 MHz	Single-core mobile
Core Solo	1.06 to 1.83 GHz	533 or 667 MHz	Single-core mobile
Pentium Family			
Pentium Extreme	3.20 to 3.73 GHz	800 or 1066 MHz	2 or 4 MB cache, dual-core for gaming
Pentium 4 Extreme	3.20 to 3.46 GHz	800 or 1066 MHz	2 MB cache, high performance
Pentium Dual-Core	1.6 to 2.6 GHz	800 MHz	1 or 2 MB cache, dual-core, mobile, and desktop
Pentium D	2.66 to 3.6 GHz	533 or 800 MHz	2 or 4 MB cache, dual-core, desktop
Pentium M	1.0 to 2.26 GHz	400 or 533 MHz	1 or 2 MB cache, mobile
Pentium	1.6 to 2.7 GHz	533 or 800 MHz	1 MB cache, dual-core, desktop, or mobile

Table 6-1 Current Intel processors

Intel Processors (cont'd.)

Processor	Clock Speed	Front Side Bus	Description
Pentium 4	2.8 to 3.8 GHz	800 MHz	256 K to 2 MB cache, single-core, desktop, or mobile
Mobile Pentium 4	2.8 to 3.46 GHz	533 MHz	512 K or 1 MB cache, single-core, mobile
Celeron Family			
Celeron	1.6 to 2.2 GHz	667 or 800 MHz	128 KB to 1 MB cache, for basic computing, desktop, and mobile
Celeron D	2.13 to 3.6 GHz	533 MHz	256 KB to 512 KB cache, some only 32-bit processing, desktop
Celeron M	900 MHz to 2.16 GHz	400 to 667 MHz	128 KB to 1 MB cache, some only 32-bit processing, mobile
Atom Family			
Atom	800 MHz to 1.86 GHz	400 or 533 MHz	512 K or 1 MB cache, single-core, low-end desktop, or mobile

Table 6-1 Current Intel processors (continued)

Intel Processors (cont'd.)

- Processor identification
 - Processor number
 - Example: Core 2 Quad processors
 - Use five-character value beginning with “Q”
 - eSpec number printed on processor
 - Intel Processor Spec Finder site identifies exact processor
- Centrino technology improves laptop performance
 - Processor, chipset, wireless network adapter interconnected as a unit

AMD Processors

Processor	Core Speed	Description
Phenom Family		
Phenom II X3	2.6 to 2.8 GHz	7 to 9 MB cache
Phenom II X4	2.5 to 3.0 GHz	5 to 7 MB cache
Phenom X4 Quad-Core	2.1 to 2.6 GHz	8 MB cache
Phenom X3 Triple-Core	1.9 to 2.5 GHz	3 MB cache
Athlon Family		
Athlon 64	1.8 to 2.8 GHz	2 MB cache
Athlon 64 X2 Dual-Core	1.9 to 3.1 GHz	2 MB cache, business computing
Athlon FX	2.2 to 3.0 GHz	1 to 2 MB cache, for extreme gaming
Sempron Family		
Sempron	1.6 to 2.3 GHz	1 MB cache, basic computing
Mobile Processors		
Turion X2 Ultra Dual-Core	2.1 to 2.4 GHz	2 MB cache, for thin and light notebooks
Turion X2 Dual-Core	1.9 to 2.2 GHz	1 MB cache
Athlon 64 X2	1.6 GHz	1 MB cache, for high-performance notebooks
Athlon Neo	1.6 GHz	512 MB cache, for ultra-thin notebooks
Sempron	1.0 or 1.5 GHz	256 MB cache, for basic notebooks

Table 6-2 Current AMD processors

Cooling Methods and Devices

- Processor overheating results
 - Processor damage and instability
- Entire system overheating results
 - Sensitive electronic component damage
- Devices used to keep system cool
 - CPU fans, case fans, coolers, heat sinks, liquid cooling systems, dust-preventing tools
- Important
 - Keep processor and entire system cool

Coolers, Fans, and Heat Sinks

- Cooler sits on top of processor
 - Maintains 90–110 degrees F temperature
 - Consists of fan, heat sink
 - Made of aluminum, copper, combination of both
 - Bracketed to motherboard using wire, plastic clip
 - Thermal compound eliminates air pockets
 - Fan power cord connects to 4-pin fan header



Figure 6-9 A cooler sits on top of a processor to help keep it cool
Courtesy: Course Technology/Cengage Learning

Coolers, Fans, and Heat Sinks (cont'd.)

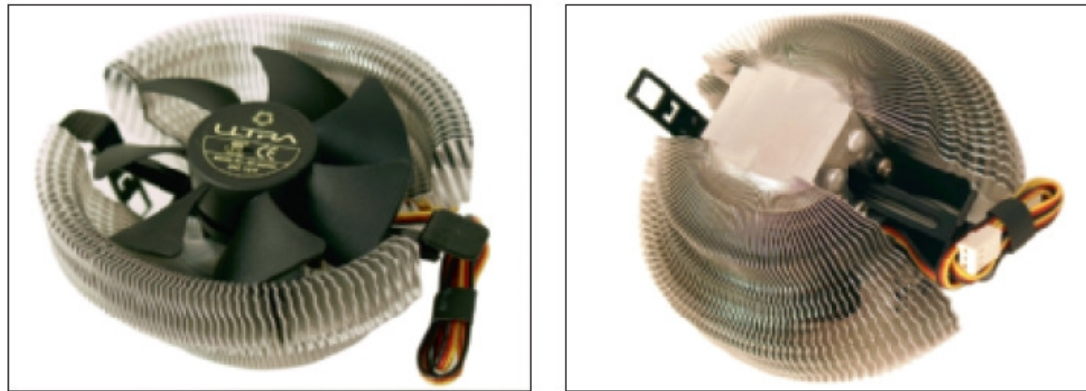

Figure 6-9 A cooler sits on top of a processor to help keep it cool
Courtesy: Course Technology/Cengage Learning

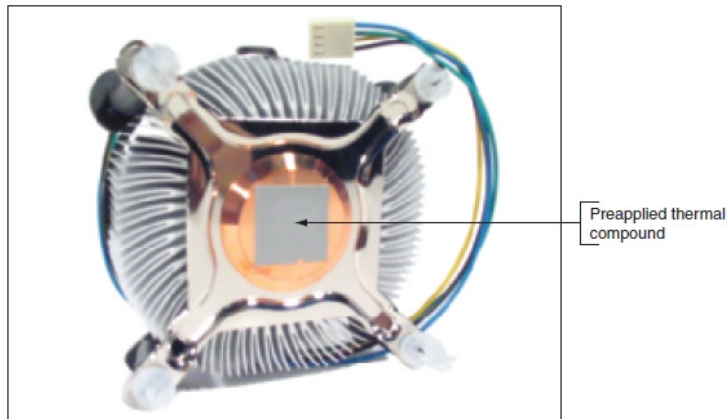

Figure 6-11 Thermal compound is already stuck to the bottom of this cooler that was purchased boxed with the processor
Courtesy: Course Technology/Cengage Learning

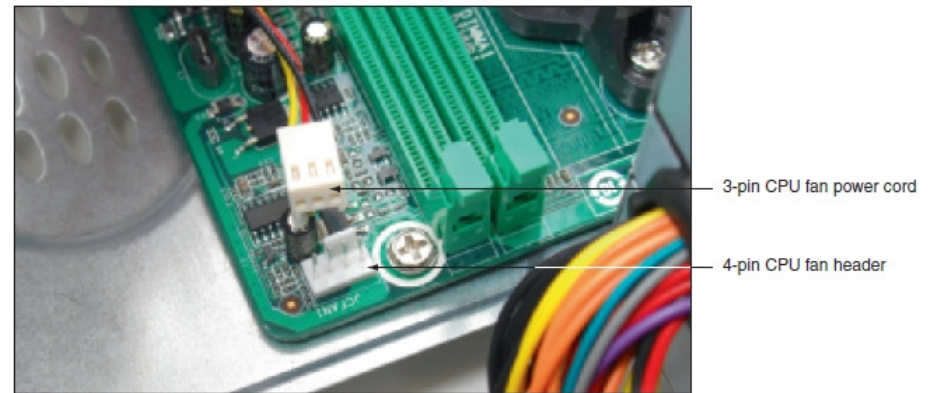

Figure 6-12 A cooler fan gets its power from a 4-pin PWM header on the motherboard
Courtesy: Course Technology/Cengage Learning

Case Fans and Other Fans and Heat Sinks

- Rear case fan draws air out of the case
 - High-end systems have seven or eight fans
- BTX form factor: fewer fans required
- Ball-bearing case fans last longer
- Cooling graphic cards
 - Some come with with fan on side
 - Heat sinks or fans to mount on card may be used
 - Fan card mounted next to graphics card may be used
 - For additional cooling consider a RAM cooler

Liquid Cooling Systems

- Exotic systems hobbyists use for overclocking
 - Refrigeration
 - Units containing small refrigerator compressor inside case
 - Can reduce temperatures to below zero
 - Peltiers
 - Heat sink carrying an electrical charge
 - Acts as an electrical thermal transfer device
 - Water coolers (most popular)
 - Small pump sits inside computer case
 - Tubes move liquid around components and away from them where fans cool the liquid

Dealing with Dust

- Dust insulates PC parts like a blanket
 - Causes overheating
- Dust inside fans
 - Jams fans, causing overheated system
- Ridding PC of dust
 - Make it a part of regular preventive maintenance
 - Tools
 - Antistatic vacuum
 - Compressed air

Selecting and Installing a Processor

- PC repair technician tasks
 - Assemble PC from parts
 - Exchange faulty processor
 - Add a processor
 - Upgrade existing processor
- Must know how to:
 - Match processor to system
 - Install processor on motherboard

Select a Processor to Match System Needs

- First requirement
 - Select processor motherboard is designed to support
- Select best processor meeting general system requirements and user needs
 - May have to sacrifice performance for cost
- General steps
 - Read motherboard documentation
 - Select processor by comparing processors board supports
 - Select cooler assembly

Install a Processor

- Installing an Intel processor in socket 1366
 - 1. Read and follow all directions
 - 2. Use a ground bracelet
 - 3. Open the socket
 - 4. Lift socket load plate
 - 5. Remove socket protective cover
 - 6. Remove processor protective cover
 - 7. Lower processor straight down into the socket
 - 8. Verify processor aligned correctly in the socket
 - 9. Return lever to its locked position

Install a Processor (cont'd.)

- Installing an Intel processor in socket 1366 (cont'd.)
 - General steps to install the cooler
 - Understand how cooler posts work
 - Apply thermal compound if necessary
 - Verify locking pins turned perpendicular to heat sink
 - Align cooler over the processor
 - Push down on each locking pin until it pops into the hole
 - Connect power cord from cooler fan to motherboard
 - Check BIOS setup to verify the system recognized processor after system up and running

Install a Processor (cont'd.)

- Installing an Intel processor in socket 775
 - Socket 775 has a lever and socket cover
 - Summary of installation steps
 - 1. Use ground bracelet, read all directions
 - 2. Release lever from the socket, lift socket cover
 - 3. Place processor in the socket
 - 4. Close the socket cover
 - 5. Apply thermal compound and install cooler
 - 6. Connect fan power cord to power connection
 - After components installed, verify system works

Install a Processor (cont'd.)

- Installing an Intel processor in socket 478
 - Similar to socket 775 installation
 - Summary of installation steps
 - 1. Open the socket, open the load plate, carefully install the processor, return lever to its position
 - 2. Apply thermal compound and install cooler
 - 3. Connect fan power cord to power connection
 - After components installed, verify system works

Install a Processor (cont'd.)

- Installing an AMD processor in socket AM2+
 - Summary of installation steps
 - 1. Use ground bracelet, read all directions
 - 2. Open the lever
 - 3. Place processor in the socket
 - 4. Verify processor pins sitting slightly into the holes
 - 5. Press the lever down and gently into position
 - 6. Apply thermal compound and install cooler
 - 7. Connect fan power cord to power connection
 - After components installed, verify system works

BIOS Power Management Settings for the Processor

- Advanced Configuration and Power Interface (ACPI)
 - Current power management standards
 - Used by BIOS, hardware, and OS
 - Four modes indicate power-saving function levels
 - S1 state: hard drive, monitor turned off and everything else runs normally
 - S2 state: hard drive, monitor, processor turned off
 - S3 state: everything shut down except RAM and enough of the system to respond to a wake-up call
 - S4 state: everything in RAM copied to hard drive file, then system shuts down (hibernation)

BIOS Power Management Settings for the Processor (cont'd.)

- ACPI defines CPU P states
 - Saves power by lowering CPU frequency, voltage
 - P0 has highest frequency
 - Higher P state values have lower frequencies
 - EIST, PowerNow!
 - Implements P states if enabled in BIOS setup
 - If enabled in BIOS, P states are controllable by Windows power management

BIOS Power Management Settings for the Processor (cont'd.)

- ACPI defines C states
 - Processor stops its internal operations
 - Conserves power
 - C0 state: processor can execute an instruction
 - C1 through C6 states
 - Processor shuts down various internal components
 - Deeper the C state, the longer it takes for processor to wake up
 - Mobile processors usually offer more C states than desktop processors
 - Feature must be enabled in BIOS

Troubleshooting the Motherboard and Processor

- Motherboard field replaceable units (FRUs)
 - Processor
 - Processor cooler assembly
 - RAM
 - CMOS battery
 - Motherboard
- Be careful when substituting good hardware components for those suspected to be bad

Problems with Installations

- Check simple things first
 - Verify motherboard supports processor
 - Check cooling fan installation
 - Remove processor, examine, reinstall
 - Reinstall old processor, flash BIOS, install new processor
- Check other system items
 - System and monitor plugs, peripheral connections
 - Case door closure, power switches, voltage
 - OS drivers
 - Various motherboard connections

Problems with the Motherboard or Processor

- Use BIOS jumpers to reset passwords
- Verify CMOS battery
 - Replace if necessary
- Symptoms of failing motherboard or processor
 - System begins to boot, then powers down
 - Error message displayed during boot
 - System unstable, hangs, freezes at odd times
 - Intermittent Windows or hard drive errors occur
 - Motherboard components or connected devices do not work

Problems with the Motherboard or Processor (cont'd.)

- Check the simple things first
 - Review power saving features
 - Look at applications or OS
 - Look at power cords, hard drives, overheating, failed RAM, power supply
 - Reduce system to essentials
 - Remove unnecessary hardware
 - See if problem resolved

Problems with the Motherboard or Processor (cont'd.)

- Hanging system problem persists
 - Assume processor or motherboard at fault
 - Verify solid installation of components and connectors
 - Check BIOS setup, allow BIOS to report on full POST
 - Flash BIOS to update firmware
 - Look for physical damage
 - Run diagnostic tests from motherboard CD
 - Update board component drivers
 - Disable failed components
 - Verify motherboard supports processor
 - Exchange processor or motherboard

Problems with Overheating

- Temperature inside case
 - Never exceed 100 degrees F (38 degrees C)
 - Tools to monitor operating temperature
 - BIOS readings, temperature sensor, utility software
 - Symptoms of system overheating
 - System hangs, freezes at odd times, or a few moments after boot starts
 - Windows error during boot (blue screen of death)
 - Cannot hear fan running or fan makes whining sound
 - Cannot feel air being pulled into or out of the case

Problems with Overheating (cont'd.)

- Simple things to solve overheating problems
 - Verify temperature in BIOS
 - Remove dust
 - Check airflow inside case
 - Install additional fans, chassis air guide (if possible)
 - Replace missing faceplates and slot covers
 - Verify cables and cooler connection
 - Allow case to breath
 - Check for overclocking and too many peripherals
 - Flash BIOS or replace thermal compound

Problems with Overheating (cont'd.)

- More drastic solutions
 - Consider case design
 - Use power supply with vents on bottom and front
 - Use intake fan on case front to pull air into the case
 - Use a chassis air guide (CAG)

Boot Problems Before the Operating System Loads

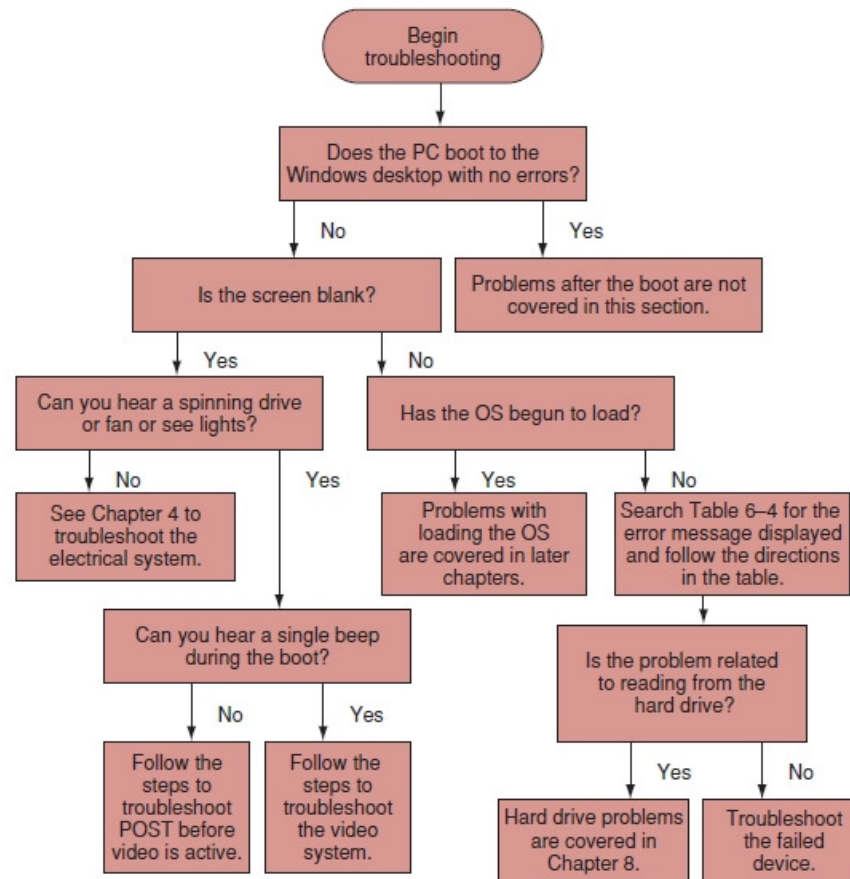

Figure 6-56 Use this flowchart when first facing a computer problem
Courtesy: Course Technology/Cengage Learning

Boot Problems Before the Operating System Loads (cont'd.)

- Troubleshooting POST before video active
 - Error messages on screen
 - Indicates video and electrical system working
 - For blank screen, listen to beep codes
 - If no beeps are heard suspect other components

Beeps During POST	Description
One beep followed by three, four, or five beeps	Motherboard problems, possibly with DMA, BIOS setup chip, timer, or system bus. Most likely the motherboard will need replacing.
Two beeps	The POST numeric code is displayed on the monitor. See the list of numeric codes later in this section.
Two beeps followed by three, four, or five beeps	First 64 K of RAM has errors. The solution is to replace RAM, which is covered in Chapter 7.
Three beeps followed by three, four, or five beeps	Keyboard controller failed or video controller failed. Most likely these are embedded components on the motherboard.
Four beeps followed by two, three, or four beeps	Problem with serial or parallel ports or system timer, which probably means the motherboard must be replaced.
Continuous beeps	Problem with power supply. The power supply might need replacing; see Chapter 4. Sometimes a continuous beep can also mean something is holding down a key on the keyboard.
Siren sound	The processor has overheated.

Table 6-3 Beep Codes and Their Meanings

Boot Problems Before the Operating System Loads (cont'd.)

- Troubleshooting video
 - If one beep during boot and a blank screen:
 - BIOS successfully completed POST including test of video card
 - Possible monitor problem
 - Is monitor electrical cable plugged in?
 - Is monitor turned on?
 - Is monitor cable plugged into video port?
 - Try a different monitor, monitor cable

Boot Problems Before the Operating System Loads (cont'd.)

- Troubleshooting error messages during boot
- Error message sources
 - After video active
 - Hardware device failed POST
 - After POST
 - Startup BIOS turned to hard drive to find an OS
 - Could not read from drive
 - After BootMgr or Ntldr in control
 - Could not find OS files to load the OS

Error Message	Meaning of the Error Message
PROCESSOR_THERMAL_TRIP_ERROR	The processor overheated and the system has restarted.
MULTI_BIT_ECC_ERROR SINGLE_BIT_ECC_ERROR	Memory failure; replace RAM.
CMOS_BATTERY_ERROR	The CMOS battery most likely needs replacing.
CMOS_CHECKSUM_ERROR	CMOS RAM has given an error. Try flashing BIOS.
MEMORY_SIZE_DECREASE_ERROR	A RAM module is not working; replace RAM.
INTRUDER_DETECTION_ERROR	An intrusion detection device installed on the motherboard has detected that the computer case was opened.
MEM_OPTIMAL_ERROR	The installed memory in each slot does not match for optimal performance. Chapter 7 explains how to correct the problem.
OVERCLOCKING_FAILED. PLEASE ENTER SETUP TO RE-CONFIGURE YOUR SYSTEM.	Overclocking should be discontinued. However, this error might not be related to overclocking; it can occur when the power supply is failing.
Hard drive not found Fixed disk error	The BIOS cannot locate the hard drive. How to solve hard drive problems is covered in Chapter 8.
Invalid drive specification Inaccessible boot drive	The BIOS is unable to find a hard drive. Look for errors in BIOS setup.
No boot device available Invalid boot disk	The hard drive is not formatted, or the format is corrupted, and there is no CD in the CD drive. Examine the hard drive for errors, which you will learn to do in Chapter 8.
Missing NTLDR Missing BOOTMGR	The boot loading program for the OS could not be found. Examine the hard drive for errors. How to do that is covered in Chapters 15 and 16.
Missing operating system, error loading operating system	The MBR is unable to locate or read the OS boot sector on the active partition. Boot from an OS setup CD or DVD and examine the hard drive file system for corruption.
Device or service has failed to start An error message about a reference to a device or service in the registry	These errors occur late in the boot when the OS is loading services and device drivers. How to handle these errors is covered in Chapters 15 and 16.
Device or program in registry not found	Windows might be corrupted or a device driver might be missing or corrupted. See Chapters 15 and 16 for solutions.
While Windows Vista/XP is loading, an unknown error message on a blue background is displayed and the system halts	These errors are called stop errors or blue screen errors and are usually caused by viruses, errors in the file system, a corrupted hard drive, a corrupted system file, or a hardware problem. How to handle blue screen errors is covered in Chapters 15 and 16.

Table 6-4 Error Messages and Their Meanings

Summary

- Processor: most important motherboard component
 - Basic CPU components: I/O unit, control unit, ALUs
 - Registers: high speed memory used by ALU
 - Internal cache: holds frequently used instructions
 - CPU bus: internal and external
- Overclocking
 - Running system bus or processor at a faster frequency than recommended
- Throttling offers some protection against overheating

Summary (cont'd.)

- Multiprocessing, multiple processors, and multi-core processing improve CPU performance
- Memory cache (L1, L2, or L3)
 - Holds anticipated data and instructions
 - Made of static RAM chips
- Instruction set
 - Microcode used for basic operations
- Various Intel and AMD processors available
- Many cooling options available
- Match processor to system, install and troubleshoot